



**WHERE
PRECISION
DRIVES
PRODUCTION**



SYSTEM SPECIFICATIONS

Work Area:

400 mm x 400 mm x 100 mm*
(15.75 in x 15.75 in x 3.94 in)

Repeatability:

0.025 mm
(0.001 in)

Resolution:

0.005 mm
(0.0002 in)

Motor:

Brushless DC servo

Drive Mechanism:

Ball screw

Work Payload:

11.4 kg
(25 pounds)

Software:

PathMaster® Windows® with offline image programming

Power:

110 V / 60 Hz, 220 V / 50 Hz

Air:

80 PSI dry unlubricated air

Certification:

CE certified

*Final work area subject to desired valve and tooling configuration. For more information, please contact your local PVA representative.

PVA250

BENCHTOP DISPENSING SYSTEM

The PVA250 is a programmable three-axis robot that is ideal for any dot, bead, or potting application. The PVA250 employs robust ball screw slides driven by brushless DC servo motors. An RS232 interface allows you to download up to 30 programs from your PC into the PVA250's motion controller memory for immediate recall. In production environments requiring more than 30 programs, the PC may remain tethered to the robot for virtually unlimited storage capacity. Any PVA dispensing valve or syringe applicator can be integrated with the PVA250. An optional top frame is available to fully enclose the work area if required.

The PVA250 has many integrated features including:

- ▲ A compact, tabletop design that favors portability
- ▲ Large 400 mm x 400 mm x 100 mm work area
- ▲ PathMaster® Windows®-based programming software with image import
- ▲ Coordinated motion in all three-axes simultaneously
- ▲ Remote trackball teach pendant
- ▲ Front panel LCD screen with function keys

For more information on PVA's dispensing capabilities, please contact one of our sales representatives at (518) 371-2684.

PVA also offers the following products to improve your dispensing application:

PVA350	Benchtop selective coating / dispensing system
PVA650	Selective coating / dispensing system
PVA2000	Selective conformal coating system
PVA3000	Automated dispensing system



Pathmaster® is a registered trademark of Precision Valve & Automation, Inc.
Windows® is a registered trademark of Microsoft Corporation.

15 Solar Drive
Halfmoon NY 12065
tel 518 371 2684
fx 518 371 2688
info@pva.net

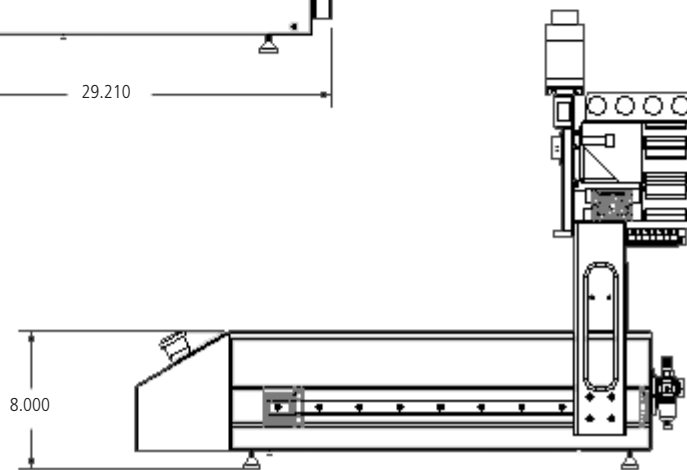
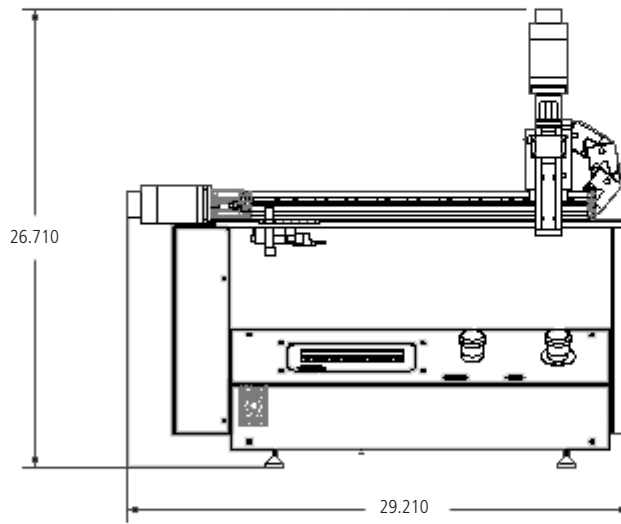
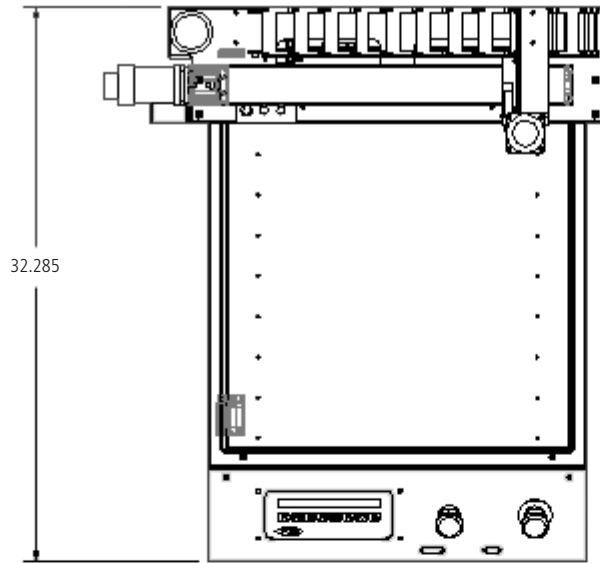

15 Solar Drive
Halfmoon NY 12065
tel 518 371 2684
fx 518 371 2688
info@pva.net